

DEAD CENTER

FEATURES ;

- Accuracy guaranteed to 0,002mm TIR (0,0001").
- Excellent for built-in tail stock machines.
- Works on all CNC machines.
- Heat-treated point to HRC 60±2.
- Meets the rigid requirements of CNC turning and grinding machine.
- Draw-off nut is for easily take out from tail stock.
- Carbide point available (DCC TYPE).
- Carbide point to HRa 90±5.

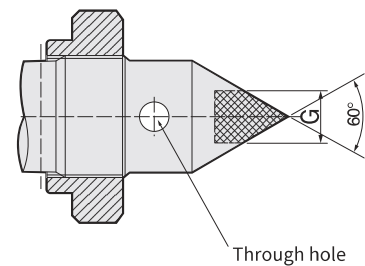
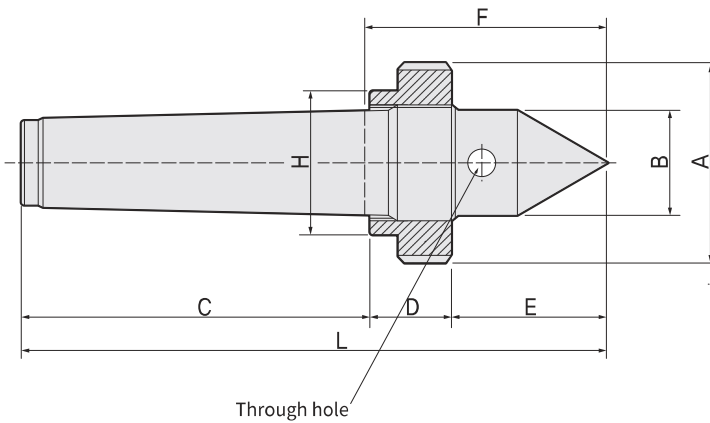

Available

Carbide Tipped Points

DCC-TYPE

- MT3 : 132003 · MT6 : 132006
- MT4 : 132004
- MT5 : 132005

Dimension

Unit : mm, kg

MODEL	MT	A	B	C	D	E	F	H	G	L	Weight
131003 (132003)	3	50	24	82	16	42	59	40	10	140	0.8
131004 (132004)	4	60	32	104	24	47	72,5	43	14	175	1.3
131005 (132005)	5	80	45	131	30	60	93	58	18	221	3.0
131006 (132006)	6	100	60	187	30	72	107	78	30	289	6.9

※(MODEL NO):Carbide Tip type.